



MOTORSPORT SOUTH AFRICA

Association incorporated under section 21
Reg. No. 1995/05605/08

VAT Reg. No. 45 7015 1219

First Floor, 9 (formerly 108) Monza Close, Kyalami Park, Midrand. P.O. Box 11499 Vorna Valley, 1686, South Africa
Telephone: 0861 MSA MSA (0861 672 672) Fax: 0866 123 456 Website: www.motorsport.co.za E-mail: adrian@motorsportsa.co.za

MSA FORMULA FORD CIRCULAR 1/2010

156833/144

It is hereby confirmed that 1600cc Duratec-engined cars will be able to take part in the Formula Ford national championship series in 2010. Duratec-engined cars will compete together with the Zetec-engined cars, all in one class, and in accordance with the below regulations:

Technical regulations for Formula Ford cars fitted with 1600cc Duratec engines

ARTICLE 1: DEFINITIONS

- 1.1 Formula Ford car (Duratec)
- 1.2 Bodywork
- 1.3 Ground Clearance
- 1.4 Minimum weight
- 1.5 Date of car build
- 1.6 Sprung Suspension
- 1.7 Wheel
- 1.8 Intake system
- 1.9 Ceramic materials
- 1.10 Composite materials
- 1.11 High volume components

ARTICLE 2: REGULATIONS

- 2.1 The role of Ford Motor Company
- 2.2 Publication date for amendments
- 2.3 Permanent compliance with regulations

ARTICLE 3: BODYWORK AND DIMENSIONS

- 3.1 Car Dimensions
- 3.2 Front nose
- 3.3 Bodywork
- 3.4 Bodywork shape
- 3.5 Bodywork mounting
- 3.6 Rear bodywork
- 3.7 Lower rear bodywork
- 3.8 Drivers compartment
- 3.9 Floor

ARTICLE 4: WEIGHT

- 4.1 Minimum weight
- 4.2 Ballast

ARTICLE 5: ENGINE

- 5.1 General
- 5.2 Permitted Engine
- 5.3 Engine modifications
- 5.4 Engine Position
- 5.5 Induction System
- 5.6 Cylinder Head (including valves)
- 5.7 Engine Covers
- 5.8 Camshafts
- 5.9 Compression Ratio
- 5.10 Cylinder Block
- 5.11 Connecting Rods
- 5.12 Crankshaft
- 5.13 Piston
- 5.14 Oil System
- 5.15 Oil Pan
- 5.16 Oil Pump
- 5.17 Oil Pressure Sensor
- 5.18 Front cover
- 5.19 Oil Lines
- 5.20 Oil Filter
- 5.21 Cooling System
- 5.22 Radiators
- 5.23 Fuel System
- 5.24 Flywheel and Clutch
- 5.25 Exhaust System
- 5.26 Engine sealing and scrutineering

ARTICLE 6: FUEL TANKS, PIPING & SYSTEM

- 6.1 Fuel Tanks
- 6.2 Fuel Pipes
- 6.3 Fuel Filler
- 6.4 Fuel Pump

ARTICLE 7: OIL TANKS

- 7.1 Location of Oil Tanks

ARTICLE 8: ELECTRICAL SYSTEMS

- 8.1 Starter
- 8.2 Alternator
- 8.3 Battery
- 8.4 Powertrain Control Module
- 8.5 Wiring harness
- 8.6 Ignition system
- 8.7 Sensors
- 8.8 Timing beacon
- 8.9 Pumps
- 8.10 Power feeds
- 8.11 Electronic dashboards and data logging equipment
- 8.12 Data Logger
- 8.13 Rear Light

ARTICLE 9: TRANSMISSION

- 9.1 Gearbox
- 9.2 Drive
- 9.3 Final drive

ARTICLE 10: SUSPENSION AND STEERING

- 10.1 Principles
- 10.2 Dampers
- 10.3 Wishbones

- 10.4 Intrusion of suspension parts
- 10.5 Anti-roll bars
- 10.6 Coatings
- 10.7 Steering

ARTICLE 11: BRAKES

- 11.1 Separate Circuits
- 11.2 Brake Discs
- 11.3 Brake Callipers
- 11.4 Cooling Ducts
- 11.5 Brake Pressure Modulation

ARTICLE 12: WHEELS & TYRES

- 12.1 Location
- 12.2 Wheel Material
- 12.3 Dimensions
- 12.4 Maximum Number of Wheels
- 12.5 Wheel Attachment
- 12.6 Tyre Type
- 12.7 Pressure Control Valves
- 12.8 Tyre heaters
- 12.9 Wheel Spacers

ARTICLE 13: COCKPIT

- 13.1 Cockpit Opening
- 13.2 Internal Cross Section
- 13.3 Feet Position
- 13.4 Steering Wheel

ARTICLE 14: SAFETY EQUIPMENT

- 14.1 Fire Extinguishers
- 14.2 Master Switch
- 14.3 Rear View Mirrors
- 14.4 Safety Belts
- 14.5 HANS device:

ARTICLE 15: SAFETY STRUCTURES

- 15.1 Regulations
- 15.2 Roll Structures
- 15.3 Chassis Survival Cell
- 15.4 The chassis
- 15.5 Head Protection
- 15.6 Frontal Protection
- 15.7 Lateral Protection Structure
- 15.8 Cockpit side protection

ARTICLE 16: FUEL

- 16.1 Fuel
- 16.2 Fuel testing

APPENDIX A:

Table of single seater dimensions.

APPENDIX C:

Tyres.

APPENDIX D:

Drawings and tables to support technical regulations.

INTRODUCTION

It is the intention of the Formula Ford Association that these 2010 regulations for Formula Ford with the 1600cc Duratec engine, are based on the prior 2009 UK Formula Ford 1600cc Duratec regulations. Minimum changes other than those necessitated by issues highlighted during previous season and MSA safety requirements will be changed. It is believed that most Zetec chassis from approx MY 2003 can be updated to meet these requirements.

These regulations are intended for use by experienced and competent motorsport teams and manufacturers and assume that anyone attempting a whole car build has a background in this motor sport discipline. In this respect any team building a car should ensure that they have full familiarity with all MSA / Ford regulations relevant to this category of motorsport and in particular that the car is built in conformity with all these requirements. For safety and security, modifications to the chassis structure or to the roll over hoop should be completed by the original manufacturer. Teams should also ensure that all installed safety equipment meets all MSA or FIA safety standards. Cars built before 31 December 2009 are eligible for the SA National Championship.

ARTICLE 1: DEFINITIONS

- 1.1 Formula Ford car (Duratec)**
Four wheel single-seater racing car fitted with a Ford 1600cc 16 Valve 'Duratec' petrol engine, and designed solely for speed races on circuits or closed courses.
- 1.2 Bodywork:**
All entirely sprung parts of the car in contact with the external air stream, except the rollover structures and the parts definitely associated with the mechanical functioning of the engine, transmission and running gear. Airboxes, radiators and engine exhausts are considered to be part of the bodywork.
- 1.3 Ground Clearance:**
The clearance between the ground and the lowest part of the bodywork, and/or of the suspended part of the car, in normal trim with the driver aboard.
- 1.4 Minimum weight:**
The minimum weight must be the weight of the car in the condition in which it crosses the finishing line and enters parc -ferme, or at any time during the competition and/or practice.
The minimum car plus driver weight will include the driver dressed for the competition with all required personal safety items.
- 1.5 Date of car build:**
Cars built before 1st January xxxx (or 1.1.xx) is interpreted to indicate cars built for the season indicated as shown by the year code. Consequently cars built to the new or revised specification, but finished before that date will still be defined as new season cars.
- 1.6 Sprung suspension:**
The means whereby all complete wheels are suspended from the body/chassis unit by a spring medium.
- 1.7 Wheel:**
Wheel: Flange and rim. Complete wheel: Flange, rim and tyre.
- 1.8 Intake system:**
All the elements between the cylinder head and the external side of the air filter.
- 1.9 Ceramic materials:**
Ceramic Materials (e.g. AL₂O₃, SiC, B₄C, Ti₅Si₃, SiO₂, Si₃N₄) – These are inorganic, non-metallic solids.
- 1.10 Composite:**
Material formed from several distinct components, the association of which provides the whole with properties which none of the components taken separately possesses. High strength composites include components made with Carbon and or aramid fibres.
- 1.11 High volume components:**
Are those from series production vehicles which have been produced in numbers greater than 25,000 in 12 consecutive months.

ARTICLE 2: REGULATIONS

- 2.1 The role of Ford Motor Company:**
The technical regulations for Formula Ford cars are issued by Ford Motor Company.
- 2.2 Publication date for amendments:**
Each year in January, The Formula Ford Association will endeavour to publish all changes made to these regulations. All such changes will take effect on the 1st January that year.
- 2.3 Permanent compliance with regulations:**

Automobiles must comply with these regulations in their entirety at all times during an event. Changes made for safety reasons may come into force without notice.

ARTICLE 3: BODYWORK AND DIMENSIONS

3.1 Car Dimensions:

See table of single seater dimensions. (Appendix A).

3.2 Front nose:

The forward extremity of the nose of the car shall be less than 200mm from the ground.

3.3 Bodywork:

Any device designed to aerodynamically augment the down thrust on the vehicle is prohibited, as are aerofoils, fins or spoilers of any type. Body shapes that decrease drag without influencing down force are authorised. The bodywork must totally enclose the engine inlet manifold and filter with an opening for the passage of air. The uppermost surface of the bodywork must not extend more than 25mm above the top surface of the rollover hoop. See additional note in dimensions table, appendix A. Have positive fastenings for all hinged or detachable parts of the bodywork. Not have skirts, bridging devices or any form of aerodynamic device between the chassis and the ground/track. Any specific part of the car influencing its aerodynamic performance must:

- i) comply with rules relating to bodywork.
- ii) be rigidly secured to the entirely sprung part of the vehicle.
- iii) remain immobile in relation to the vehicle..

3.4 Bodywork shape:

3.4.1) The shape of the bodywork must not include external concave surfaces, except where flat or convex surfaces are joined. When these surfaces are joined, no part of either surface, when viewed in a vertical section, must occupy the same Z coordinate, except at the joint. No flat surfaces are permitted within 15° of the horizontal.

3.4.2) The bodywork can be shaped to fit over the chassis. However, any such body shape that can be deemed, or even thought, to produce an aerodynamic effect that could result in down force will be prohibited. Note; Guidance must be sought from Ford Motor Company at the design stage to avoid any potential problems.

3.4.3) Any bodywork in front of the front bulkhead shall have no external concave surfaces.

3.5 Bodywork mounting:

Bodywork may only be mounted directly to the chassis, undertray, or suspension mounting points. Suspension mounting points may be covered by bodywork, but only if this is an integral part of the bodywork, and not an addition to the main bodywork. Only original factory specification parts supplied by the

Manufacturer can be used in front of the forward bulkhead. No additional material can be added.

3.6 Rear bodywork:

The bodywork must not extend rearwards past the rearmost point of the gearbox housing (no gearbox extensions permitted).

3.7 Lower rear bodywork:

Located below the rear wheel centre line: is only permitted alongside and beneath the engine and can only extend from behind the cockpit to a line drawn through the rear wheel axis. The incorporation of suspension or other fairings in this bodywork or separately is prohibited.

3.8 Drivers compartment:

Be fitted with bodywork with a driver's compartment isolated from the engine, gearbox, transmission shafts, brakes, road wheels, their operating linkages and attachments, petrol tanks, oil tanks, water header tanks and catch tanks.

3.9 Floor:

3.9.1) Have a complete Floor of adequate strength rigidly supported within the driver compartment.

3.9.2) Have any undertray provided with drainage holes to prevent accumulation of liquids.

3.9.3) Any extension of the floor rearward of the main rear bulkhead (under the engine) must conform to the same reference plane and tolerances as the flat floor.

ARTICLE 4: WEIGHT

4.1 Minimum weight:

The minimum weight of car plus driver, at any time during competition shall be 500kg.

4.2 Ballast:

Ballast can be used provided it is secured in such a way that tools are required for its removal. It must be possible to fix seals if deemed necessary by the scrutineers.

ARTICLE 5: ENGINE

5.1 General:

- 5.1.1) This paragraph confirms previous and future statements that no rework may be carried out on any component unless specifically authorised by the regulations. The engine and associated parts must remain exactly as produced by the Ford Motor Company unless expressly detailed in these regulations..
- 5.1.2) The expression 'Standard', 'Standard production', or similar expression is deemed to imply that the part has been manufactured by Ford Motor Company, or a Ford Motor Company Ltd. authorised sub contractor, for specific use on a specific model of the vehicle or engine. Consequently for these championship rules only parts manufactured specifically for the Ford 1600cc, 16 Valve Duratec engine in its production form may be used.
N.B. Care must be exercised in the choice of replacement parts, as variations of this engine exist. See last two pages for parts listing.

5.2 Permitted Engine:

- 5.2.1) The only permitted base engine is the Ford 1600cc, 16 Valve Duratec engine in its 100PS Non-VCT (Focus & Fiesta) form (code FYJA or FYJB) with nominal bore 79.0mm and stroke 81.4mm, fitted with the components in the mandatory engine performance kit . No other parts may be fitted to the engine unless specifically detailed in these regulations.
- 5.2.2) Production tolerances are permitted providing the total swept volume does not exceed 1600.00 cc.

5.3 Engine modifications:

- 5.3.1) If the regulation allows a change, then that authorization would allow the change to be carried out.
However any statement defining minimum weight or dimensions does not grant permission for rework to obtain these minimum values, unless carried out in accordance with these regulations.
- 5.3.2) No treatment that alters in any way the surface finish, hardness, or other property of the original production component is allowed.
- 5.3.3) **The Formula** Ford Association reserve's the right to prohibit the use of specific components introduced as production changes, if in the opinion of the Formula Ford Association they are deemed to have a performance advantage. If in doubt contact the Formula Ford Association or the series Technical consultant / scrutineer.
- 5.3.4) Any machining marks on cast components resulting from manufacturing procedures will not cause disqualification. Only machining and component preparation carried out by Ford Motor Company Ltd or by a Ford Motor Company Ltd authorised sub-contractor is allowed unless otherwise specified. The scrutineers decision will be final (based on advice from Ford Manufacturing) if a dispute arises regarding the amount of tool, or other marks, that are evident in any particular component.
- 5.3.5) Any production deburring or imperfection removal during initial manufacture may not be modified or extended. The scrutineers decision will be final (based on advice from Ford Manufacturing) if a dispute arises regarding the amount of tool, or other marks, that are evident in any particular component.
- 5.3.6) The addition of any material (metal, plastic, or composite) whether by welding, bonding, encapsulation or encasement to any component is prohibited. However, specific repair of the mounting points of the cylinder block to the transmission or chassis is allowed, whilst other casting repairs may be allowed with prior written approval of the series scrutineer.
- 5.3.7) Balancing of reciprocating and rotating parts is permitted only by removal of metal from locations so provided by the manufacturer as detailed in Appendix D. The declaration of minimum weight in the regulations does not permit the freedom to rework a component to achieve this weight. The freedom to balance is specifically for this purpose only therefore at least one piston and connecting rod from the set must remain completely untouched.
- 5.3.8) The use of non-standard replacement fasteners, nuts, bolts, screws, studs and washers which are not connected with, or which do not support, any moving parts of the engine or its compulsorily retained accessories is permitted. Freedom granted to any fastener does not allow for freedom to move items relative to each other. For components that are granted the freedom for the fitment of a key or dowel, then material may be removed to allow the fitting of the key or dowel. Only one hole or keyway per component is allowed.
- 5.3.9) The use of thread locking compounds is permitted.
- 5.3.10) Gaskets are free except for the cylinder head (Part N° 4M5G-6051-CA for reference) and exhaust manifold (Part N° 2S6G-9448-DA for reference), which must be standard Ford manufacture for the engine.
- 5.3.11) Any process of cleaning may be used on any component providing the surface finish,

- which must remain standard, is not affected.
- 5.3.12)** Forced induction is prohibited. Ram Air generated by the forward motion of the car is not considered as forced induction.
- 5.3.13)** Exterior surfaces only of the complete engine assembly may be protected by paint or similar means. No internal component or surface may be coated by any protective finish. Other Ford produced aluminium components may be protected only on their external surfaces by a transparent clear varnish, or similar.
- 5.3.14)** Engine/transmission mounts attaching to standard Ford components must retain the standard dimensions of the boss or other attachment point without modification.
- 5.3.15)** In the determination of the engine compression ratio it will not be permitted to remove carbon deposits from the pistons and the cylinder head.
- 5.4 Engine Position:**
The engine must be mounted upright, and aligned fore and aft in the chassis. The engine crankshaft centre line must be on the longitudinal centre line of the vehicle.
- 5.5 Induction System:**
- 5.5.1 Inlet Manifold:**
The mandatory Formula Ford inlet manifold Part N° MS06FF- 9424-AA, unmodified in any way must be used. 4-off of the mandatory Formula Ford inlet manifold gaskets Part N° MS06FF-9441-AA, unmodified in any way must be used.
- 5.5.2 Throttle Body:**
The mandatory Formula Ford throttle body, spindle and butterfly plate Part N° MS06FF-9E926-AA, unmodified in any way must be used. No polishing or re-profiling is permitted. The maximum throttle internal diameter is 55.10mm. The mandatory Formula Ford throttle position sensor Part N° 90TF-9B989-BA, unmodified in any way must be fitted to the throttle body and connected to the engine wiring harness..
- 5.5.3 Air Filter:**
The mandatory Formula Ford air filter Part N° MS06FF-9601- AA unmodified in any way must be used. All the air entering the engine must pass through the air filter prior to the throttle body. No pipe extension or air horn/trumpet/bell mouth is allowed inside the air filter unit. The air filter must be fitted to the throttle body without any intermediary device.
- 5.5.4)** The induction air filter unit may be placed in a cold air chamber. This chamber may use the mating face between the throttle body and intake manifold for the sole purpose of support, must not allow any air flow through the mating faces and will be a maximum of 3mm thick. The whole of the cold air chamber must fit inside the bodywork and respect Art 3. No air trumpets/horns/bell mouths are permitted outside the bodywork.
- 5.5.5)** Ford Motor Company reserves the right to impose the use of an inlet restrictor which will be placed between the throttle body and the inlet manifold. If fitted, the restrictor must be unmodified in any way and all combustion air must pass through the restrictor.
- 5.5.6)** Any means of reducing intake air temperature is prohibited. Any form of water or other gaseous or liquid injection or induction is prohibited.
- 5.6 Cylinder Head (including valves):**
- 5.6.1)** No work that removes, adds, replaces, or transfers material is allowed on the cylinder head with the following exceptions:
- i). Simple cleaning which does not alter in any way the shape of the component.
 - ii). Minimal material removal from the head face to correct combustion chamber volume and/or reclaim head flatness. No internal rework of any combustion chamber is permitted.
 - iii). Fitting of replacement valve seat insert to a position that replicates the standard closed valve position.
- 5.6.2)** It is permitted, as a means of repair, to replace damaged valve guides and valve seats by replacement valve guides and valve seat inserts to all standard materials and dimensions.
- 5.6.3)** The cam cover assembly cannot be modified or replaced. The standard oil filler cap can be replaced by a suitable fluid tight blank.
- 5.6.4)** All valve train components, other than the shims used to adjust valve clearance may not be modified or replaced. The tappets cannot be modified in any way. Valves must remain standard, no re-profiling or polishing is permitted. The original seat angle must be maintained. Standard valve stem seals must be retained.
- | | |
|-------------------------------------|--------------|
| Distance apart at centres (inlet) | 33.00mm |
| Distance apart at centres (exhaust) | 31.50mm |
| Maximum face diameter (inlet) | 30.25mm |
| Maximum face diameter (exhaust) | 24.25mm |
| Overall length (inlet) | 98.98±0.25mm |

Overall length (exhaust)	101.40±0.25mm
Valve stem diameter, inlet	5.97mm
Valve stem diameter, exhaust	5.96mm.

5.7 Engine Covers:

The standard camshaft cover must be used and cannot be modified. Its colour may be changed. The standard cam belt covers must be used but may be locally modified to allow mounting of a FEAD idler pulley and/or engine mount. Any remaining gaps must be filled.

5.8 Camshafts:

5.8.1) The only permitted camshafts are those specified for Formula Ford use, conforming to the lift tables in Art 5.8.6 and 5.8.7, as supplied with the engine by the association. Camshafts must remain entirely unmodified and must be fully manufactured and ground by the designated supplier. Only the production surface finish is permitted. Shot peening, shot blasting or polishing are prohibited.

5.8.2) Standard cam pulleys must be used, but can be locally reworked to permit keying to the camshaft by woodruff key or dowel. The cam belt tensioner may be mechanically locked.

5.8.3) The cam profile is defined by determination of lift (L minus l) against a flat footed follower at various angles (Ø). Standard Ford tolerances apply to camshaft drawing and lift tables below.

5.8.4) The angular setting of the camshafts relative to the crankshaft is free but must remain fixed and not vary throughout the entire engine operating speed range.

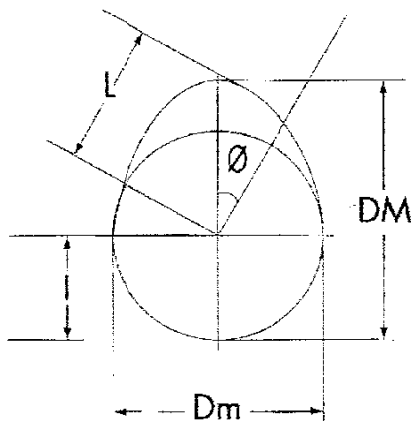

5.8.5) Intake Camshaft Lift Table:

Ø DEGREES	L open mm	L close mm
0	9.30	9.30
5	9.23	9.23
10	9.00	9.00
15	8.63	8.63
20	8.12	8.12
25	7.47	7.47
30	6.70	6.69
35	5.82	5.80
40	4.82	4.80
45	3.74	3.70
50	2.60	2.55
55	1.49	1.45
60	0.65	0.62
65	0.32	0.32
70	0.22	0.24
75	0.12	0.16
80	0.02	0.09
85	0.00	0.02
90	0.00	0.00
DM	39.30	
Dm	30.00	

5.8.6) Exhaust Camshaft Lift Table:

Ø DEGREES	L open mm	L close mm
0	8.13	8.13
5	8.06	8.06
10	7.84	7.84
15	7.48	7.48
20	6.99	6.99
25	6.36	6.36
30	5.62	5.62
35	4.76	4.76
40	3.80	3.80
45	2.76	2.76
50	1.70	1.70
55	0.78	0.78
60	0.40	0.40
65	0.30	0.30
70	0.20	0.20
75	0.10	0.10
80	0.02	0.02
85	0.00	0.00
90	0.00	0.00
DM	38.13	
Dm	30.00	

5.8.7) Valve Springs:

Formula Ford specific valve springs and retainers (Part N°s MS06FF-6513-AA & MS06FF-6A536-AA) must be used.

5.9 Compression Ratio:

5.9.1) The maximum compression ratio will be 11.15:1 and be controlled as follows:

- i). Minimum combustion volume in the cylinder head (with the spark plug fitted) = 30cm³.
- ii). Standard Ford cylinder head gasket with a minimum compressed thickness of 0.30mm, and a minimum diameter of cylinder aperture of 79.50mm. The piston will sit below the block head face by a minimum of 1.00mm when the piston is at TDC.

5.9.2) The cylinder block head face surface may be machined whilst respecting 5.9.1 ii).

5.10 Cylinder Block:

5.10.1) It is permitted, as means of repair, to replace cylinder bores with 'dry' cast iron cylinder liners. 'Nicasil' or any other types of bore plating / treatments are prohibited. All materials and dimensions must remain Ford standard.

5.10.2) The crankcase breather may be blanked off. Crankcase breather blanking plate MS06FF-6A785-AA is available. Ensure that no air and/or oil can escape from the engine other than through pipe-work to a catch tank.

5.11 Connecting Rods:

5.11.1) Standard Ford supplied production connecting rods must be used (Ford Part N° 98MM-6200-DC for reference only). Machining is permitted to remove metal from the big end cap machine locator areas to achieve balance only; the area for balancing is defined in Appendix D drawing 5. Although balancing is permitted by these regulations Ford does not recommend such machining. Polishing is prohibited. Note: connecting rod caps are fractured and therefore matched to the connecting rod. Do not mix connecting rod caps.

5.11.2) Connecting rod bolts are free subject to them remaining in ferrous material and their fitment requiring no machining of the connecting rod or bearing cap to fit, and the minimum weights respected.

5.12 Crankshaft:

5.12.1) The standard Ford supplied production crankshaft must be used (Ford Part N° 98MM-6303-CA/CB). Spot machining (by radial drilling or milling) to achieve balance is permitted. (Area for balancing defined in Appendix D Drawing 3). Polishing is prohibited. Crankshaft minimum weight is 9750g (including gearbox input shaft spigot bearing). Crankshaft journals must remain within Ford positional tolerances if a repair regrind is carried out.

5.12.2) The mandatory crank damper pulley (MS06FF-6B321-AA) must be retained but may be modified to remove the additional (smaller) pulley. Additional drives to oil pump, alternator etc. may use this pulley, or extra pulleys mounted in front of the crankshaft damper.

- 5.12.3) It is not permitted to alter the number of bearings or fit bearings of less than standard production width.
 - 5.12.4) The crank journals may be reground for reclaim, as long as the minimum crank weight is respected. Only Ford Standard oversize and undersize bearings are permitted and cannot be modified. Only bearings made specifically for the engine, and marketed by companies that supply Ford with original equipment bearings are allowed. Chamfering of the entry/exit holes of oil ways is permitted.
 - 5.12.5) A marker must be fitted which accurately aligns the crankshaft to the cylinder block at No.1 piston TDC. This marker must be visible and fully accessible to the scrutineers without removing any component other than external body panels, and without removing the engine from the car.
 - 5.12.6) It is permitted to machine the nose of the crankshaft to fit a woodruff key to allow positive location of the cam drive sprocket.
- 5.13 Piston:**
- 5.13.1) Standard Ford supplied production pistons must be used (Part N° 4M5G-6110-EC/ED, for reference only) unmodified in any way except for machining to achieve balance as detailed in Appendix D Drawing 4. At least one piston from the set must be completely untouched. Although balancing is permitted by these regulations Ford does not recommend such machining.
 - 5.13.2) All piston rings must be fitted; piston rings must be standard production.
 - 5.13.3) The combustion chamber face of the piston may not be modified. The minimum weight of the connecting-rod and piston assembly shall be 695g. (Complete piston with rings and pin, and connecting-rod with bolts but excluding crankshaft bearings).
- 5.14 Oil System:**
An oil based lubricating system is mandatory. The Formula Ford specific dry sump kit and pump kit must be used. Existing standard production oil ways, linings or oil grooves may be enlarged, but no additional ones are permitted. Addition of material to facilitate an increase in oil way size is not permitted.
- 5.15 Oil Pan:**
The mandatory Formula Ford dry sump oil pan, Part N° MS06/08FF-6675-AA/AB unmodified in any way must be used. Oil coolers are free. The standard production baffle (windage tray) may be modified, removed, or replaced by another. Any replaced baffle shall have no other function and be no larger in surface area than the replaced production part.
- 5.16 Oil Pump:**
The mandatory Formula Ford oil pump Part N° MS06/08FF-6600-AA (2 scavenge & 1 pressure pump) unmodified in any way must be used. Pump location is free but it must be driven from the nose of the crankshaft using the mandatory crank and pump pulleys. The internal engine pressure oil pump is not required. Removal of the following standard parts only is allowed: - Oil pump inner and outer rotor, oil suction pipe and strainer and pressure control valve.
- 5.17 Oil Pressure and Temperature Sensors:**
- 5.17.1) The mandatory oil pressure sensor Part N° MS06FF-9278-AA must be remote mounted onto the rear bulkhead and connected into the main oil gallery with braided hose and screwed connectors. It must be connected to the engine loom.
 - 5.17.2) The mandatory oil temperature sensor must be fitted into the main oil gallery and must be connected to the engine loom.
- 5.18 Front Cover:**
The front cover assembly, within which the standard oil pressure pump is housed, must be used and remain unmodified.
- 5.19 Oil Lines:**
All lubricating oil lines, which carry oil at a nominal working pressure of 1 bar or above, must have a minimum burst pressure of 70 bar (1,000psi) and a minimum operating temperature of 232°C (450°F). When flexible, these lines must have threaded connectors and an outer braid resistant to abrasion and flame (will not sustain combustion). All other oil containing lines must be made from hose material and fittings that meet the minimum operating temperatures stated above, and have adequate burst strength. No oil lines are permitted in driver cockpit area.
- 5.20 Oil Filter:**
The oil filter is free but must remain connected into the lubricating oil circuit in its standard location on the side of the block.
- 5.21 Cooling System:**
- 5.21.1) A water based liquid cooling system is mandatory.
 - 5.21.2) The standard production water pump must be retained. Other pulleys, belts and their fasteners, driving the water pump and other accessories are free.

- 5.21.3) No other pump or motor may be used to circulate or assist circulation of the coolant liquid.
 - 5.21.4) The standard thermostat/pump outlet housing (Ford Part N°. 2S6G-9K478-BA) may be replaced by a bespoke part with a single hose connection to suit the installation of the engine in the chassis. The thermostat may be removed. If fitted, the thermostat must be in the original standard location. The standard thermostat(s) for the engine are (Part N° 4M5G-8575-ZA 82°C or -YA 74 °C).
 - 5.21.5) The combined water outlet housing / coil pack mounting (Ford Part N° 1N1G-8594-AB for reference only) must be retained. It is permissible to re-orientate the water outlet only to suit the chassis installation. Unused car heater connections may be blanked off. The engine coolant temperature sensor (Ford Part N° F5AF-12A648-AB for reference only) must be fitted and connected to the loom.
- 5.22 Radiators:**
- 5.22.1) The radiator and associated pipes are free.
 - 5.22.2) The radiator if mounted in a housing or incorporating a cool air scoop or deflector must comply with bodywork regulations.
 - 5.22.3) Ducting to the radiators, or other items requiring cooling, inside the lateral protection structure is free. Slots and other openings may be inserted into the top surface of the Lateral Protection structure, but these must not be connected to the radiator directly by separate ductwork.
 - 5.22.4) Radiator Caps. Only a single cap is permitted. The cap should be located or shielded in such a way that hot water or steam cannot scald the driver of the vehicle if it becomes opened or broken in an accident.
- 5.23 Fuel System:**
- 5.23.1) Fuel Injector: The mandatory fuel injectors Part N° 98MF-9F593-BB unmodified in any way must be used and remain in their original position. A maximum of 1 per cylinder (total 4) is allowed.
 - 5.23.2) Fuel Rail: A modified fuel rail assembly Part N° MS06FF-9D280-AA must be used. The mandatory fuel rail Part N° 2N1U-9H487-AB will be modified in the following way: The fuel pressure regulator will be removed. The #1 cylinder end of the rail will be fitted with dash-3 connector welded in place, for the fuel pressure sensor. The other end must have a dash-6 screwed fitting welded on.
 - 5.23.3) Fuel Pressure Regulator: The mandatory fuel pressure regulator Part N° MS06FF-9C968-AA must be securely mounted, and connected into the main fuel pressure line.
 - 5.23.4) Fuel Pressure: With an engine at correct operating temperature, and the engine idling, the pressure in the fuel rail as measured by the fuel rail pressure sensor shall be 500±10 kPA, (5±0.1Bar).
 - 5.23.5) Fuel Pressure Sensor: A fuel pressure sensor must be remote mounted onto the rear bulkhead and connected into the fuel system via the end of the fuel rail using braid hose and screwed connectors. It must be connected to the chassis loom .
- 5.24 Flywheel and Clutch:**
- 5.24.1) Flywheel: The mandatory Formula Ford flywheel, Part N° MS06FF-6375-AA unmodified in any way, except for balance as specified in Appendix D, must be used. For rectification the clutch mating face may be resurfaced, provided the minimum weight is respected. Flywheel minimum permitted weight = 4300g (excluding all flywheel mounting bolts & dowels).
 - 5.24.2) Clutch cover: The mandatory Formula Ford clutch pressure plate, unmodified in anyway must be used. Clutch Cover minimum permitted weight = 1835g (excluding clutch cover bolts and dowels).
 - 5.24.3) A maximum of one mandatory clutch plate is allowed,
 - 5.24.4) Flywheel bolts and locating dowels must remain standard production components.
- 5.25 Exhaust System:**
- 5.25.1 **Manifold:**
The exhaust manifold shape is free, but must be manufactured in compliance with Appendix D Drawing 2 and made from mild or stainless steel tubing with a minimum wall thickness of 1mm. A boss location is specified for the HEGO sensor, which must be fitted. The exhaust manifold must connect via a gas tight joint directly with a single exhaust pipe.
 - 5.25.2 **Silencers:**
The mandatory Formula Ford silencer available from the Formula Ford Association in compliance with Appendix D, Drawing 2.
 - 5.25.3 **System:**
The Exhaust Pipe may not extend more than 400mm beyond the rear wheel axis.

- 5.25.4 Noise:**
 At all times the car must conform to the noise requirements of the circuit, the series regulations, and any ASN specific vehicle regulations as regards position of the exhaust outlet. The exhaust must exit to the rear of the car. The complete exhaust system up to the end of the final pipe shall remain gas tight at all times. The end of the exhaust pipe must be cut square to the pipe centre line.
 A maximum noise level of 108dB(A), measured at 0.5 ± 0.1 5m from the tail pipe exit, and at 45° to the pipe centre line will be enforced unless a greater degree of silencing is required by the event organisers, in which case this must be specified in advance in the event final regulations. The engine speed for noise measurement purposes will be $\frac{3}{4}$ max rpm. If specific sporting or technical regulations specify a mandatory silencer it must be used and fitted after the catalyst, irrespective of the exhaust noise generated without it.
- 5.26 Engine sealing and scrutineering:**
- 5.26.1 Access:**
 An access hole must be provided in the bell housing to allow the clutch to be sealed to the flywheel without removal of the engine from the car
- 5.26.2 Sealing:**
 Tamper proof paint seals or wire seals will be used for all cases when sealing of any component is required. All engines should have provision for scrutineers wire seals. 2mm diameter holes pre-drilled in readily accessible locations on installed engines must be available:-
- i.) Sump - two holes through the cylinder block/ sump joint flange, one either side of the engine.
 - ii) Cam Cover - at least two retaining screw heads must be cross drilled.
 - iii) Inlet Manifold - at least two retaining bolt heads to the cylinder head must be cross drilled.
 - iv) The inlet tract complete, and the throttle body and air restrictor must be so arranged as to permit sealing by wire. The exhaust manifold and exhaust pipe containing the catalyst must be capable of sealing with wire seals.

ARTICLE 6: FUEL TANKS PIPING & SYSTEM

- 6.1 Fuel Tanks:**
- 6.1.1)** Only FT3 or superior specification FIA specification fuel tanks are allowed. It is recommended that all new cars built from 01-01-2009 should have a fuel cell which is suitable for bio-fuels up to 85% ethanol content. The fuel tank must be totally isolated from the cockpit area, and the housing must have suitable drain holes to ensure no spilt fuel is retained in this structure. Tanks should be located so that they are given maximum protection by the structure of the vehicle. MSA / FIA recognized vent valves must be fitted to the breather to ensure no fuel spillage in the case of the car inverting.
- 6.1.2)** Only fuel tanks bearing a label from the original manufacturing company detailing a production date that indicates that it is less than 5 years old, or for a further 2 years if the tank has been returned to the original manufacturer and been granted an extension, will be permitted.
- 6.1.3)** Tank Fillers, Vents, and Caps: Tank fillers and caps must not protrude beyond the bodywork or be situated within the driver/passenger compartment. The caps must have an efficient locking action to reduce the risk of opening during an accident and ensure closing after refuelling. Air vents must be at least 250mm to the rear of the cockpit.
- 6.1.4)** In the case of a vehicle with the fuel tank placed immediately behind the driver, the liquid proof structure enclosing the fuel tank must be protected by complete bulkheads, ensuring no fuel can reach the driver in the case of an accident or other fuel spillage whilst seated in the car.
- 6.1.5)** At the end of practice and the race at least 3 litres of fuel from the tank of the competing car must be available to the scrutineers (pumped out via the cars standard fuel pump for analysis. Compliance with minimum weight for the car will be taken before the fuel is removed. Any Industry recognised method of fuel checking may be employed.
- 6.2 Fuel Pipes:**
- 6.2.1)** All fuel pipes that contain fuel under pressure must have a minimum burst pressure of 70 bar at a minimum operating temperature of 135°C. It is recommended that all new cars built from 01-01-2009 should have fuel pipes which are suitable for bio-fuels up to 85% ethanol content.
- 6.2.2)** Automatic fuel cut-off: Ford strongly recommend that all fuel feed pipes going to the engine should be provided with automatic cut-off valves located directly on the fuel tank

which automatically close all fuel lines under pressure if one of these lines in the fuel system is fractured or leaks.

- 6.2.3)** No fuel pipes are allowed within the driver cockpit area.
 - 6.2.4)** Be equipped with an effective method of stopping Fuel supply operable by the driver when normally seated.
 - 6.2.5)** To facilitate the repeated fitting of screwed connectors for the aluminium fuel rail it will be permitted to have short adaptor hoses (to the same specification) between the engine and chassis system.
- 6.3 Fuel Filler:**
Should be designed and located to reduce risk of damage. The filler cap should not be liable to open in the case of an accident. The filler pipe to the tank should be of minimum possible length and the cap must not protrude beyond the bodywork. Additionally the filler cap must not be located over any hot object.
- 6.4 Fuel Pump:**
- 6.4.1)** The electric high pressure fuel pump and fuel filter assembly (maximum volume 0.5 litre) must be mounted within the area defined by the chassis rails and not directly in the cockpit area. The fuel pump shall be capable of maintaining the normal operating fuel rail pressure of 500kPA (5.0 Bar) under all circumstances. It must be controlled solely by the ECU, via a relay (min 40A).
 - 6.4.2)** It is permitted to fit a low pressure fuel pump and fuel collector (maximum volume 1 litre) prior to the high pressure fuel pump. This must be mounted within the area defined by the chassis rails and not directly in the cockpit area. It must be controlled solely by the ECU, via a relay (min 40A).

ARTICLE 7: OIL TANKS

7.1 Location of Oil Tanks:

All oil tanks mounted outside the main chassis structure must be surrounded by crushable structure of minimum thickness 10mm.

ARTICLE 8: ELECTRICAL SYSTEMS

All wiring should be secured and well protected to reduce the risk of chafing and damage and the risk of fire from an electrical short circuit. No electrical components located in the Cockpit area are permitted which has a working voltage greater than 15 Volts, with the exception of the engine ECU and its associated loom.

8.1 Starter:

8.1.1 Starter Motor:

A starter motor, with an electrical source of energy carried on board the car, and able to be controlled by the driver when normally in their seat must be fitted in the original position on the engine. The starter motor itself is free but it must use the standard mountings on the engine without modification.

8.1.2 Starter button:

The Ford Power starter button may be used in its entirety.

8.2 Alternator:

A 12 Volt (nominal) alternator must be fitted. The alternator may be driven from either the engine front pulley or transmission drive shaft/flange. The minimum output of the alternator shall be 240 Watts, and the installation shall ensure that this output is available at all times whilst the car is circulating on the race track. Only high volume automotive alternators may be used.

8.3 Battery:

8.3.1) Only a single battery may be used and will be of a dry cell construction. 'Wet' batteries and 'gel' batteries are prohibited.

8.3.2) The battery must be capable of demonstrating at least 3 engine starts without external recharge, or assistance, at any time during practice, the race, or in Parc-Ferme.

8.3.3) A supplementary external source of energy temporarily connected to the car may be used to start the engine whilst in the pit area, but cannot be used whilst checking. See 8.3.2.

8.3.4) The battery terminals must be covered to protect from short circuit / producing sparks in all circumstances. The battery earth lead, if not readily distinguishable, must be identified by a yellow marking along its entire length.

8.4 Powertrain Control Modules:

8.4.1) The mandatory Formula Ford PCM, MBE 967 unmodified, in any way must be used, plus any other PCM specifically defined, and notified to competitors by the championship organisers. The Sporting Regulations for the event has the right to specify which, or all, of

the PCM calibrations may be used. It is prohibited to modify the software contained in the PCM.

- 8.4.2)** The PCM diagnostic connector must be positioned in an accessible position on the outside of the vehicle, adjacent to the battery master switch allowing scrutineers free access to it at all times. The free access must allow for the condition of the driver seated in the car and fully prepared to take part in the competition.
 - 8.4.3)** The engine PCM may be exchanged, or electronically interrogated at any time (including the time allocated for practice) upon the request of a designated official from the company promoting the championship or from an ASN designated official.
 - 8.4.4)** Unless officially requested by the series scrutineer the PCM must be set-up to record the standard logging parameters as supplied in the PCM.
- 8.5 Wiring harness:**
The mandatory Formula Ford engine management wiring loom unmodified in any way must be used. No rework or modification to this loom is permitted, with the exception of replacing damaged connectors (like for like).
- 8.6 Ignition system:**
- 8.6.1 Sparking Plug:**
The mandatory standard spark plug Part N° AYFS22C or AYFS22CB unmodified in any way must be used in the standard position in the combustion chamber.
 - 8.6.2 Coil:**
The standard coil unit unmodified in any way must be used and may not be repositioned. The standard HT leads to the sparking plugs must be used without modification. It is prohibited to use any other method or component to trigger, distribute or time the ignition or injection.
- 8.7 Sensors:**
- 8.7.1 Standard production sensors:**
All standard production engine sensors which have any influence whatsoever on the engine management system must be retained in the standard position and in working order. It is not permitted to reposition positional sensors. The knock sensor (if fitted) is not required and may be removed from the engine. It is not permitted to change the strength or form of any of the sensor signals to, or the outputs from, the PCM. For the avoidance of doubt this means any / all additional sensors are prohibited as are any modifications to the standard production ones for this engine. It is prohibited to fit an extra crankshaft speed sensor.
 - 8.7.2 Vehicle speed sensor:**
A vehicle speed sensor may be fitted on the left front wheel and connected to the engine control unit via the chassis connector for the data logging/display system may be used.
- 8.8 Pumps:**
The electric high pressure fuel pump, and low pressure pump (if fitted) must be activated through a relay (minimum 40 amp capacity) and shall be controlled solely by the engine PCM.
- 8.9 Power feeds:**
The power feed to the PCM must be fed from the switched side of the ignition switch. The power feed to the injectors and coil Power feed must be fed from the switched side of the battery master switch.
- 8.10 Electronic dashboards and data logging equipment:**
Are allowed subject to them having no influence whatsoever on the behaviour of the car during competition. All information obtained from any data logging or storage equipment shall be made freely available to the Scrutineer on request.
- 8.11 Data Logger:**
The event scrutineers reserve the right to require a competitor to carry a Ford supplied data logger on the car at any time during the event. The unit will be located inside the vehicle near the existing diagnostic connector.
- 8.12 Rear Light:**
Red Warning Light: An LED, rearward facing, red warning light must be located within 100mm of the vertical centre line of the vehicle and be clearly visible from the rear. When viewed from the rear the light must not be obstructed by any part of the vehicle. The rear warning light must be energized when visibility is poor. These lights will be FIA homologated.

ARTICLE 9: TRANSMISSION

- 9.1 Gearbox:**
 - 9.1.1)** The gearbox must contain not more than four forward gears and include an operable reverse gear, capable of being engaged by the driver whilst normally seated. The ratios

are free.

- 9.1.2) Gear change must be manual in operation, and no signal transmitted to, or connection may be made in any form between the gearbox, or any part of the gear change system, and any part of the engine or engine control systems (mechanical, electrical, or electronic).
 - 9.1.3) A gearbox change mechanism that only allows sequential selection of the gears is not permitted.
 - 9.1.4) The only position for the main gear cluster will be wholly behind the rear axle output shaft centre line, and in line with the crankshaft centre line. Transverse, vertical, or other non in-line configuration is not permitted.
- 9.2 **Drive:**
Rear wheel drive only is permitted.
- 9.3 **Final drive:**
- 9.3.1) Final drive ratio is free.
 - 9.3.2) Torque biasing, limited slip and locked differentials are prohibited. Non ferrous differential components are prohibited, with the exception that unmodified OEM supplied, non ferrous bevel gear thrust washers are permitted provided that, at any temperature, they do not provide any form of torque biasing etc.

ARTICLE 10: SUSPENSION AND STEERING

- 10.1 **Principles:**
- 10.1.1) Be fitted with sprung suspension between the wheels and the chassis. Suspension must be controlled to avoid fouling of wheels on chassis or bodywork. The springing medium must not consist solely of bolts located through flexible bushes or mountings.
 - 10.1.2) There must be movement of the wheels to give suspension travel in excess of any flexibility in the attachments.
 - 10.1.3) It is not permitted to construct any suspension member in the form of an aerofoil or to incorporate a spoiler in the construction of any suspension member. A symmetrical oval tube is not considered an aerofoil. The push/pull rod from the wheel uprights to the damper mechanism may use a modified oval tube, but the bottom surface must be a mirror image of the top surface, and the long axis must be parallel to the ground.
 - 10.1.4) Suspension components must be the same effective length on both sides of the vehicle, and their mounting points must be equal distance from the chassis centre line.
 - 10.1.5) Active suspensions are prohibited, as is any system that allows control of the flexibility of the suspension springs, shock absorption and trim height when the car is moving.
- 10.2 **Dampers:**
The damper casing design is free. They must be ferrous or light alloy units and separate reservoirs for fluid and/or gas are permitted. The shock absorber casing is defined as the item which contains the piston, fluid/gas, and moving parts which control the damping action. Any form of active damping is prohibited. Any method of altering the damper performance by the driver whilst seated in the car is prohibited
- 10.3 **Suspension parts:**
The wishbones, and push / pull rods must be of steel or other ferrous material. All other suspension members must be made from a homogeneous metallic material with no composite materials allowed. It is permitted to incorporate suspension mounting points on the engine and transmission assembly.
- 10.4 **Intrusion of suspension parts:**
In order to prevent intrusion of suspension parts into the chassis cell during a side impact, each member of every front suspension component with two inboard mountings must be joined by a link as close to the chassis cell as practical. The anti-intrusion bars must have a minimum outside diameter of 11mm, and a minimum wall thickness of 1mm. Any slip joints in their construction must be effectively locked with threaded fasteners during competition.
- 10.5 **Anti-roll bars:**
Anti-roll bars for front and/or rear suspension capable of adjustment by the driver when seated in the car are forbidden.
- 10.6 **Coatings:**
Chromium plating of any steel suspension components is forbidden
- 10.7 **Steering:**
- 10.7.1) The steering must consist of a mechanical link between the driver and the front wheels. Rear wheel steering is prohibited. All other parts of steering system are free.
 - 10.7.2) Have steering movement controlled to avoid fouling of the front wheels on chassis or bodywork.

ARTICLE 11: BRAKES

11.1 Separate Circuits:

All cars must have a brake system which has at least two separate circuits operated by the same pedal. This system must be designed so that if leakage or failure occurs in one circuit, the pedal shall still operate the brakes on at least two wheels. Vehicles must have brakes on all wheels.

11.2 Brake Discs:

Only brake discs made predominantly from ferrous material are permitted.

11.3 Brake Callipers:

Callipers may be ferrous or aluminium alloy castings with a maximum of two working cylinders per calliper. Brake pad materials, including carbon metallic are free.

11.4 Hand operated brakes:

For the sole purpose of assisting the driver during gradient starts, a simple cable operated brake assist system may be used. This may not in any way affect the performance of the main braking system and may not be connected to the hydraulic circuits. It must be solely mechanical.

11.5 Cooling Ducts:

Brake cooling ducts are not permitted.

11.6 Brake Pressure Modulation:

Anti-Lock brakes and power braking are forbidden.

ARTICLE 12: WHEELS & TYRES

12.1 Location:

Complete wheels must be external to the bodywork in plan view.

12.2 Wheel Material:

The material of the complete wheel assembly (Rim and mounting flange) shall be ferrous material or aluminium alloy. Magnesium alloy is not permitted.

12.3 Dimensions:

13 inch diameter wheels with a maximum rim width of 6 inch for the front and 7 inch for the rear are the only wheels permitted.

12.4 Maximum Number of Wheels:

The number of wheels is fixed at four

12.5 Wheel Attachment:

All wheels must be retained onto the hub by a minimum of four equally spaced stud and nut (or bolt) fixing.

12.6 Tyre Type:

The only tyres permitted are those listed in Appendix C. NB. The Slick and Wet tyres detailed in Appendix C are the ONLY tyres that are permitted on these wheels. See Sporting Regulations for the number of tyres permitted per event.

12.7 Pressure Control Valves:

No pressure limiting device of any kind is allowed in the wheel/tyre assembly.

12.8 Tyre heaters:

It is not permitted to pre-heat the tyres by any means. This includes tyre warmers; hot soak cabinets etc. It is not permitted to chemically change the composition of the tyre material from the 'as sold' condition.

12.9 Wheel Spacers:

Not be fitted with any Wheel Spacer exceeding 25mm in thickness or of less than hub diameter. Multiple or laminated spacers prohibited.

ARTICLE 13: COCKPIT

13.1 Cockpit Opening:

The opening giving access to the cockpit must allow a designated horizontal template to be inserted vertically into the cockpit (not considering the steering wheel, the removable seat, or any side head support) down to 250mm lower than the lowest point of the cockpit opening. This template is defined by dimensions J, K, L in Appendix A.

13.2 Internal Cross Section:

The free internal cross section of the cockpit from the soles of the driver's feet to behind the seat shall at no point be less than 70000mm². The only thing that may encroach on this area is the steering column. A free vertical section of minimum 250mm width maintained to a minimum height of 250mm with corners of maximum 50mm radius must be maintained over the whole length of the cockpit with the steering wheel removed. The driver normally seated in their driving position with the seat belts fastened and the steering wheel removed must be able to raise both legs together such that their knees reach the plane of the steering wheel in the rearwards direction; this action

must not be obstructed by any part of the car. The cockpit must be so conceived that the maximum time necessary for the driver to get out from their normal driving position does not exceed 5 seconds with all driving equipment being worn, the safety belts fastened, and the steering wheel in place in the most inconvenient position.

13.3 Feet Position:

The soles of the feet of the driver, seated in the normal driving position and with their feet on the pedals in the inoperative position, shall not be situated to the fore of the vertical plane passing through the centre line of the front wheels.

13.4 Steering Wheel:

13.4.1) Shape: The steering wheel rim must be continuously closed but the shape is free.

13.4.2) Quick Release: The steering wheel must be fitted with a quick release mechanism. Its method of release must be by pulling a concentric flange installed on the steering column behind the wheel.

13.4.3) Position: No part of the steering wheel or column, nor any part fitted to them, may be closer to the driver than a plane formed by the entire rear edge of the steering wheel rim. All parts fixed to the steering wheel must be fitted in such a way as to minimise the risk of injury in the event of a driver's head making contact with any part of the wheel assembly.

ARTICLE 14: SAFETY EQUIPMENT

General safety recommendation:

Owing to the widely varying nature of competitions and vehicles taking part in them, the Ford Motor Company Limited takes the view that it would not be in the best interests of the competitors to cover all aspects of safety precautions with mandatory regulations. Inevitably such regulations could not necessarily provide for the most appropriate safety precautions in all foreseeable circumstances. The Ford Motor Company Limited therefore draws attention to the following points so that the competitors can consider them and take precautions as seem appropriate to their own particular requirements. All personal safety equipment: overalls, underwear, helmet, boots etc. must comply with at least the minimum requirements of the ASN for the event being contested.

14.1 Fire Extinguishers:

14.1.1) A fire extinguisher/extinguishing system must be carried on all vehicles, the minimum requirement being that the system be charged with one of the permitted extinguishants and be operable by the driver whilst normally seated either by manual operation or by a mechanically / electrically assisted triggering system

14.1.2) Extinguishers will be classified as Small, Medium or Large and designated as Hand Held or Plumbed-In. Dry powder and Halon extinguishants are prohibited. Minimum Specification = Medium Plumbed-In, for discharge into both cockpit and engine compartment. Alternative: Large, plumbed-in, for discharge into both cockpit and engine compartment. As an alternative to the above, FIA homologated systems are accepted.

Table of Equivalents

Zero		
Size	AFFF	2000
Medium	2.25 Ltr	2.25 Ltr
Large	2.25 Ltr	2.25 Ltr

All capacities are minima.

14.1.3) Plumbed-In Systems (If AFFF they must be FIA/MSA homologated).

14.1.4) The Large unit should have two points of triggering, one for the driver and one outside the car for activation by Marshals etc.

14.1.5) The triggering point from the exterior must be positioned close to the Circuit Breaker (or combined with it) and must be marked by the letter "E" in red inside a white circle of at least 100mm diameter with a red edge.

14.1.6) In installing units the direction of nozzles should be carefully considered, induction, exhaust, ignition and fuel pumping systems being the most likely areas for fire to occur

14.1.7) Where possible sources of fire exist outside the engine or cockpit areas advice should be sought from the MSA, the FIA, or the National Motor Sport Authority concerning plumbed-in system installations.

14.1.8) All bottles should discharge simultaneously and must be operable in any position of the car even if inverted.

14.1.9) It is strongly recommended that plumbed-in bottles should be mounted in the fore and aft direction in the vehicle. The fitting of a pressure gauge is recommended (mandatory for

pressurised AFFF units.

- 14.1.10) Method of Operation: The preferred method of operation is electrical which should have its own source of energy for triggering, ideally with provision for checking the integrity of the systems triggering circuit.
 - 14.1.11) Installation: Particular attention should be paid to the installation and maintenance of any system, especially if it is mechanically operated. Pull cables should be fitted in such a way that no kinks or 'S' bends are formed which could cause malfunction.
 - 14.1.12) Extinguisher systems should be capable of being dismantled for the purpose of checking the weight of the extinguishant and the integrity of the cylinder, also to enable the operating system to be serviced without discharging the contents. The tare weight of the unit must be marked on the cylinder.
 - 14.1.13) All plumbed-in extinguisher systems must be in an 'ARMED' condition (i.e. be capable of being operated without the removal of any safety device) at all times whilst competing or practising in races or speed events (including during postevent scrutineering)
 - 14.1.14) Any plumbed-in extinguisher system found to be incapable of being operated will be the subject of a report to the Clerk of the Course/Stewards for possible penalty as an offence against Safety Regulations.
 - 14.1.15) Checking for correctly 'Armed' extinguisher systems, should only be carried out by MSA Scrutineers, and/or Judges of Fact nominated for that purpose.
- 14.2 **Master Switch:**
- 14.2.1) Driver Switch: The driver, when seated normally with safety belt fastened and steering wheel in place, must be able to cut off all electrical circuits to the ignition, all fuel pumps and the rear light by means of a spark proof circuit breaker switch. This switch must be located on the dashboard and must be clearly marked by a symbol showing a red spark in a white edged blue triangle.
 - 14.2.2) External Circuit Breaker: An external circuit breaker switch when operated, must isolate all electrical circuits with the exception of the circuit that operates the fire extinguishers. It must be situated on the lower main hoop of the roll-over bar. The location to be identified by a Red Spark on a white-edged blue triangle, and the 'On' and 'Off' positions clearly marked. Note: When the circuit breaker is operated there must be no power source capable of keeping the engine running.
- 14.3 **Rear View Mirrors:**
All cars must have at least two mirrors mounted so that the driver has rearward visibility on both sides of the car (minimum surface area of each mirror: 5500mm²).
- 14.4 **Safety Belts:**
- 14.4.1) Be fitted with a safety harness to be worn at all times by the driver during training practice and competition.
 - 14.4.2) The safety harness must be of a 'six point' type, incorporating two shoulder straps, one abdominal strap and two straps between the legs, with each strap having a separate fixation point on the chassis of the vehicle. Points must be located one either side of the driver, two to the rear of the driver's seat and two between the legs. The fixation points to the rear should be positioned so that the strap from the shoulder is as near horizontal as possible. It must not be located on the floor directly behind the driver. Seat belts once involved in a serious accident must be discarded. It is not permitted to mix parts of seat belts. Only complete sets as supplied by manufacturers must be used.
 - 14.4.3) Release mechanism: Only one release mechanism is permitted on each seat belt configuration and this must be available for the wearer to operate whilst seated in the competing position. Belts subjected to oil, acid or heat must be replaced. All harnesses must be currently FIA homologated.
- 14.5 **HANS device:**
Competitors are advised that the use of Head and Neck Restraint System (HANS) devices is compulsory under these regulations. Any HANS device used must comply with the FIA code.

ARTICLE 15: SAFETY STRUCTURES

- 15.1) These regulations are based the 2009 Royal Automobile Club Motor Sports Association (MSA) current Yearbook (Blue Book) rules, and specific Ford requirements.
- 15.2 **Roll Structures:**
- 15.2.1) The basic purpose of safety structures is to protect the driver. This purpose is the primary design consideration. The use of the rollover hoop to achieve or supplement aerodynamic effects is prohibited. It is not permitted to carry or pass any liquids in or through any tubes comprising part of the chassis structure, or safety ROPS.

- 15.2.2)** All cars must have two roll structures. The principal structure must be positioned behind the driver. The second structure must be in front of the steering wheel but no more than 250mm forward of the top of the steering wheel rim in any position. The two roll structures must be of sufficient height to ensure the driver's helmet and his steering wheel are at least 70mm and 50mm respectively below a line drawn between their highest points at all times.
- 15.2.3)** The Safety Roll-over structure must either comply fully with an MSA ROPS Certificate issued in 2005 or earlier or be constructed to the following requirements:
- 15.2.4)** The roll-over hoop must be symmetrical about the lengthwise centre-line of the car and of minimum height 900mm measured vertically from the base of the cockpit or 920mm measured along the line of the driver's spine from the bottom of the car seat.
- 15.2.5)** There must be at least one brace rearwards from the top of the roll-over hoop at an angle not exceeding 60° with the horizontal. This brace must be the same diameter as the roll-over hoop, if two braces are fitted to the tube the diameter may be reduced to 20-26mm the wall thickness being maintained. In addition, forward facing braces should be considered. The width inside the roll-over hoop main tubes must be 380mm minimum measured 600mm above the base of the seat. It must incorporate a cross brace to restrain the driver's head and give rearward support. The top hoop radius must not be less than 100mm measured at the centre line of the tube.
- 15.2.6)** Minimum Material steel specification: Cold drawn seamless Carbon steel 350N/mm²
Minimum Dimensions: 42.4mm diameter x 2.6mm wall thickness
- 15.2.7)** The front roll-over hoop (Hoop in front of the steering wheel) must be designed to withstand the forces given hereafter in any combination on top of this hoop:-
1.5w Lateral;
5.5w Fore and aft;
7.5w Vertical
w = 600Kg
- 15.2.8)** Each manufacturer must be able to demonstrate to the ASN:
- i) That the material used has a certificate of origin or traceability and is kept segregated from other batches of material.
 - ii) That welding procedures used produce consistent and sound welds and are regularly checked by laboratory tests.
 - iii) That they operate and maintain auditable in-house quality standards and procedures which are updated regularly.
- 15.3 Chassis Survival Cell:**
- 15.3.1)** The model year of the chassis must be clearly and indelibly stamped into a structural member of the main chassis, (or on a steel plate attached by welding on at least 3 sides to the chassis), in an area visible to scrutineers without bodywork or other component removal. All chassis's for a particular model year will be stamped in the same position.
- 15.4 The chassis:**
- The longitudinal centre line of the chassis must correspond with the longitudinal centre line of the wheel axis'. The chassis must be of tubular steel construction with no load bearing panels except bulkhead and undertray, curvature of the undertray must not exceed 25.4mm. The undertray/floor (Art 3) extends from the bulkhead forward of the pedals to the bulkhead between the fuel tank and the engine. Monocoque chassis construction is prohibited. Load bearing panels are defined as, sheet material affixed to the frame by welding or bonding or by rivets or by bolts or screws that have centres closer than 152mm. The maximum length of weld attaching the panels to the chassis shall be 25.4mm. The gap between the ends of the each weld shall be a minimum of 152 mm. Bodywork must not be used as stress bearing panels. The use of stabilised materials, composite materials using carbon and/or Kevlar reinforcement is prohibited (unless specifically permitted in these regulations). In the case of a vehicle with the fuel tank placed immediately behind the driver, a Bulkhead (a non-flammable, solid closing panel, attached to the main frame of the chassis with its fixation points less than 152mm apart around the full extremity of the panel), must be placed between the engine and the fuel tank. In addition another closing panel must be fitted between the fuel tank and the driver to prevent any fuel spillage, however caused, from reaching the driver whilst seated in the car. Gaps must be sealed with GRP or Intumescent Putty. Magnesium is prohibited for bulkheads. The tolerance on the variation in flatness of the under surface of the car between the furthest forward bulkhead, and the rear bulkhead (at the position of the Roll Over protection hoop) will be 5mm. The Lateral Protection structure base (Side pod base) can be up to 25mm above the floor defined above, but must be parallel to it, and subject to the 5mm flatness tolerance. The floor of the side pod must reflect the plan of the upper surface.

- 15.5 Head Protection:**
- 15.5.1)** A rear head restraint must be fitted, capable of restraining a 17kg mass decelerating at 5g. Dimensions to be 100mm x 100mm and located such that the driver's helmet is restrained and cannot move past it under rearward forces, or be trapped between the rollover hoop and the head restraint. It is recommended that it be within 50mm of the driver's helmet when normally seated.
- 15.5.2)** Side head restraints are mandatory for all cars the internal gap between the ears must be less than 400mm, and the side restraints must be fitted with an energy absorbing material of at least 20mm minimum thickness. Its construction must not impair the drivers ability to extricate themselves from the vehicle within the maximum time allowed. (See Art 13.2) The side head protection device may be detachable during this extradition, but its removal must form part of the extradition period. The energy absorbing material used must comply with a minimum F.I.A standard for this application.
- 15.5.3)** Side Head protection shall be installed at such a height that it ensures that the driver's helmet will contact this protection in such a manner as to reduce to a minimum any possible injury in the case of contact with it.
- 15.6 Frontal Protection:**
- 15.6.1)** The chassis must include an impact-absorbing structure fitted ahead of the front bulkhead of the tubular steel frame. This structure must be independent of the main bodywork and must be solidly fixed to the extremities of the bulkhead (i.e. with bolts requiring tools for removal). It must constitute a box of 300mm minimum length, 150mm minimum height in any vertical section and 40000mm² minimum total cross section. It must be metallic using honeycomb sandwich construction with a panel thickness of 13.9mm minimum. The main bodywork is defined as the external covering of the chassis frame from the foremost steel bulkhead to the centreline of the rear wheels.
- 15.6.2)** The impact-absorbing structure shall be fixed to the chassis with a minimum of 4 fasteners, in high quality steel using a core diameter of 6mm minimum. Irrespective of the size of the impact absorbing structure (safety foot box), the maximum total area of access holes allowed in the walls of this structure shall be 15000mm². The basic structure is defined as a unit with 5 closed sides, and 1 open side. The access hole dimensions quoted apply to any modification to the 5 closed sides. (Minimum clearance holes for the passage of steering rack / rods are not included in the calculation of this area.
- 15.7 Lateral Protection Structure:**
- 15.7.1)** Continuous panels whose projection on a vertical plane parallel to the longitudinal axis of the car shall be at least 150mm high, shall extend on either side of the car, at a minimum distance of 550mm from the car's longitudinal centre line between at least the transverse planes passing through the fuel tank rear face and the frontal extremity of the minimum cockpit opening, and at a minimum distance of 350mm from the car's longitudinal centre line between at least the transversal planes passing through the above extremity and the front rollover bar hoop. These panels shall be made from a composite material of 3000mm² minimum cross section with a honeycomb core in metal or Nomex giving adequate resistance to compression. The external skins shall be of aluminium alloy, plastic, or carbon fibre of a minimum thickness of 0.5mm or made up of another assembly of materials of equivalent efficiency. The panels must be securely attached to the flat bottom and their upper extremity to the main structure of the car in such a manner as to ensure absorption of a lateral impact. The radiators may play the role of protective panels or of transversal struts. The periphery of the bodywork covering the Lateral Protection Structure, when viewed from below, must be curved upwards with a minimum radius of 50mm, and a maximum radius of 70mm with the exception of air entry and exit openings into the Lateral Protection Structure.
- 15.8 Cockpit side protection:**
- Above the level of the Lateral Protection Structure, and up to the level of the upper chassis tube, stretching from the rear roll hoop to the front roll hoop there must be an anti-intrusion panel. This anti-intrusion panel shall be either built into the removable bodywork, or keyed into the main chassis but cannot be rigidly attached to the chassis. It can be made from glass reinforced plastic, Kevlar or aluminium skin added to the inner face of the removable body panel. Any material added must considerably improve the anti-penetration capability of the structure in the area of the driver. If the side protection is built into the bodywork alongside the driver the minimum requirement is: - a double layer, 141.75 g/m² (5oz), bi directional, laminated Kevlar (Aramide) material.

ARTICLE 16: FUEL

16.1 Fuel:

Pump fuel conforming to the MSA Competitors' and Officials' Year Book under the Terminology section must be used or equivalent specification for fuel of the country authorising the competition. It is recommended that cars built from 01-01-09 should have a fuel system fully compatible with bio-fuels which contain up to 85% ethanol.

16.2 Fuel testing:

Random fuel test samples by the scrutineer are permissible. For events that specify a single source fuel, an industry recognised fuel comparison testing machine is authorised. In this case, and on condition that the test is conducted by a qualified technician to the manufacturers instructions, then this test procedure will become the definitive test of compliance for that event.

ARTICLE 17: MISCELLANEOUS

17.1 Materials

17.1.1) The use of titanium, ceramic, high strength composites and similar materials is prohibited. Manufacturers with existing magnesium suspension uprights/knuckles will be permitted to retain these for 2009. In 2010 the use of magnesium will be prohibited. (Unless expressly permitted).

17.1.2) The use of carbon and/or Kevlar reinforcement is prohibited. (Unless expressly permitted).

17.1.3) The use of non-metallic materials for seals, bearing race cages and bearing liners i.e. rose joint bearings are permitted.

17.2 Verification:

Scrutineers are empowered to undertake any form of verification procedure necessary and may order the removal of parts from the car, incurred costs to be borne by the competitor. The right is reserved for a competitor's vehicle to be sealed for later inspection and to be removed to a Ford nominated location for examination. The competitor, or their agent, will be invited to witness this inspection and will be required to provide all the labour required to perform the vehicle or component strip. The scrutineers job is to observe and report; it is the entrant's responsibility to present any component requested by the scrutineer for inspection.

**APPENDIX A
TABLE OF SINGLE SEATER DIMENSIONS**

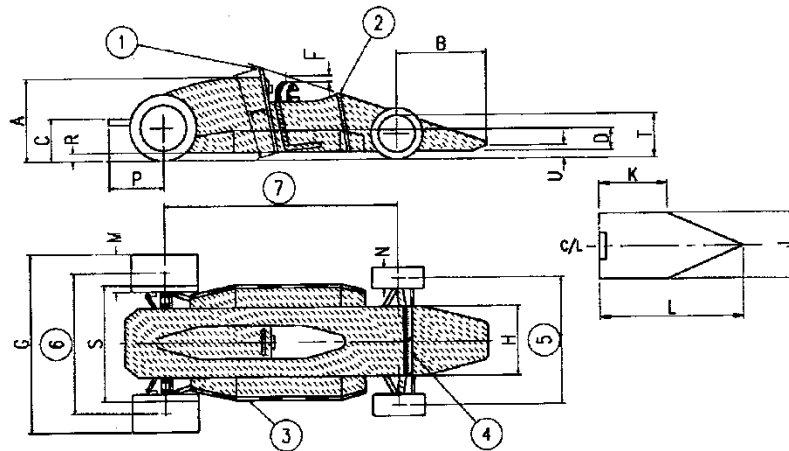

- | | |
|---------------------------------|----------------------------------|
| 1. Safety roll over bar | 2. Substantial support structure |
| 3. Lateral Protection structure | 4. Substantial structure |
| 5. Front track | 6. Rear track |
| 7. Wheelbase | |

Notes

Maximum height is measured with the driver aboard.
Maximum height excludes safety roll-over bar on which there is no maximum height.

Single seater dimensions – refer to drawing

*(A) Maximum body height measured from ground	900
(B) Maximum front overhang from front wheel axis	1000
(C) Exhaust height measured from the ground	600 Max
(D) Minimum height of Lateral Protection Structure	150
(E) Minimum safety roll-over bar length in line with drivers spine	920
(F) Minimum allowed helmet clearance	50
(G) Maximum width	1850
(H) Maximum body width behind front wheels	950
(J) Minimum cockpit opening	450
(K) Minimum cockpit parallel opening length	300
(L) Minimum cockpit overall opening length	600
(M) Maximum rear wheel width	7 inch
(N) Maximum front wheel width	6 inch
(P) Maximum exhaust length from rear wheel axis	400
(R) Minimum ground clearance	40
(S) Maximum width including lateral protection structure	1300
(T) The maximum height of any part wider than 1100mm ahead of the front wheels is not to exceed the front rim height	
(U) Maximum height of nose (see Art 4.13 for implementation date)	200
Minimum wheelbase	2000
Minimum track	1200
Wheel diameters	13 inch

ALL dimensions in mm unless specifically stated
(* Except for within 450mm rearward of the front face of the ROPS and for a maximum of 150mm either side of the centre line where bodywork may not be more than 25mm higher than the upper surface of the ROPS.)

Appendix C

TYRES

- The only approved tyres for Formula Ford cars are:
 - Pattern Size Specification No:
 - Front Tyre Slick 6.0/21.0-13 8810
 - Rear Tyre Slick 7.0/22.0-13 8811
 - Front Tyre Wet 6.0/21.0-13 7414
 - Rear Tyre Wet 7.0/22.0-13 7415
- The specification number will be moulded on one sidewall of the tyre, as will a unique serial number for that tyre.
- No mechanical (other than rubber removal by normal wear), heat or chemical treatments are permitted to the "as sold" tyres.
- Tyres Supplied by:
 - Formula Ford Association South Africa.
- See sporting regulations for the number of tyres that can be used at any race meeting.

Appendix D

Drawings and tables to support technical regulations include:

1. Valve seat dimensions
2. Exhaust system

1. Valve Seat Dimensions

Throat diameter

Inlet $26.0 \pm 0.15 \text{mm}$

Exhaust $20.0 \pm 0.125 \text{mm}$

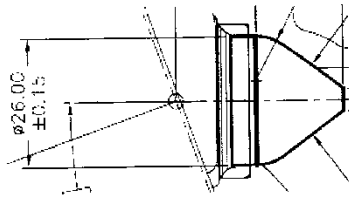

INLET

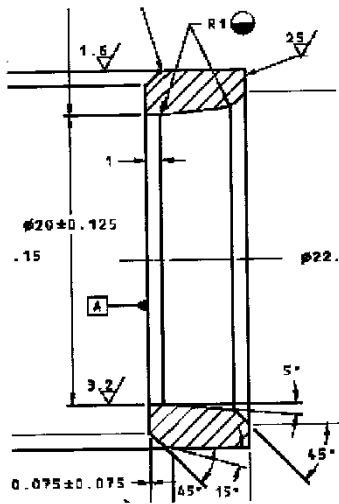

EXHAUST

2. Exhaust system layout.

Manifold to be 4 into 1 type. All primary pipes to be of same diameter.

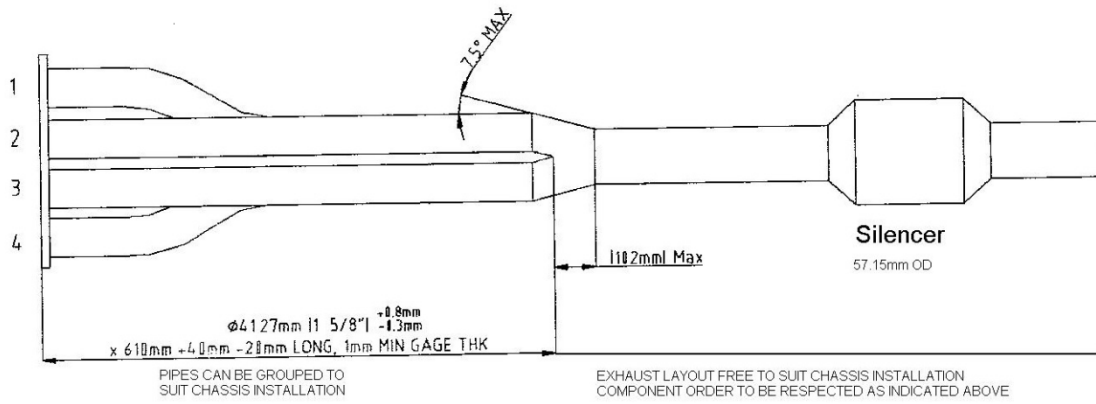

Published: 11th February 2010